

Hybrid Lift

VPL-Hybrid for Residential & Commercial Applications

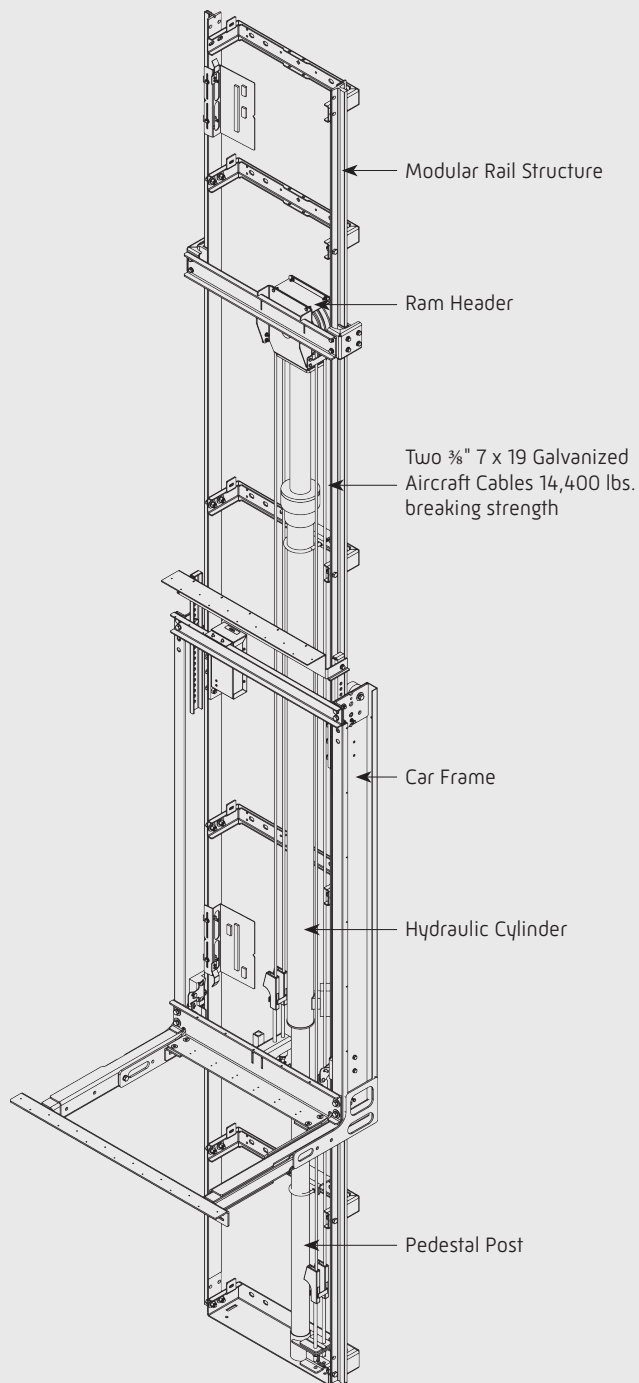

Industry Leading Warranty

- Four-year limited parts

What is a Hybrid Lift?

For commercial or residential use, the Symmetry Hybrid Lift looks and feels like an elevator, but operates like a vertical platform lift. Features include full height walls, non-load bearing ceiling and a wide variety of optional features and finishes. Symmetry also offers the flexibility to select doors that perfectly accent the decor.

Standard Features

- Travel: Maximum of 14'0" (minimum 12" between stops)
- Speed: 30 fpm
- Rated Capacity: 750-1,000 lbs.
- Pit Depth: 6" minimum (8 inches preferred)
- Stops: Two
- Opening: Same Side
- Overhead: Minimum of 94" with a 7'0" clear height
- Warranty: Four-year limited parts

Equipment

- 208/230 VAC, 60Hz, 30 amp single-phase power supply for motor controller
- 120 VAC, 60Hz, 15 amp, single-phase power supply for lighting
- Car frame assembly
- Modular 6¼ lb. T-rail structure
- Roped Hydraulic Drive System with submersed power unit

Safety Features

- Top stop switch
- Pit stop switch
- Motor controller supply disconnects (located in controller)
- Lighting supply disconnects (located in controller)
- Emergency stop switch and alarm
- Electromechanical hoistway door interlocks (doors by others)

Controls

- Programmable Logic Controller (PLC)
- Constant pressure operation
- S.M.A.R.T. system (Self-Monitoring Alert Response Technology)*
- Platform Operating Panel (COP) with LED floor position indicator**
- Landing controls with call button and LED floor position indicator**
- Automatic lighting
- Uninterruptible Power Supply (UPS) for emergency lowering in the event of a power failure*

Platform Features

- Size: Up to 18 square feet
- Interior Wall Height: 7'0"
- Interior Walls: Birch, Oak or Maple flat veneer
- Handrail: Brushed Stainless Steel
- Ceiling: Non-load bearing
- Floor: Unfinished plywood with sill set for ¾" (flooring by others)
- Lighting: Two energy-saving recessed LED lights with Black trim rings

Enter/Exit Configurations

- Same Side
 - Straight-Through
 - 3 Openings
- 90°

This brochure is intended for INFORMATIONAL PURPOSES ONLY and SHOULD NOT be used for construction.

Optional Features

- Stops: Up to six
- Custom interior wall heights
- Wall Panel: Shaker, Recessed or Raised with matching ceiling
- Lighting: Four recessed LED lights with Black, Polished Brass, Brushed Nickel or Bronze trim rings
- Fixtures: Standard Brushed Stainless Steel, also available in Polished or Blackened Stainless Steel or Solid Brass (Brushed, Polished or Oil-Rubbed), or powder-coated Black or Vintage Bronze (includes COPs, landing controls and handrails)
- ADA phone
- Interiors: Available in custom wood
- Custom factory finishes*
- "Green" material alternatives and finishes for interior*
- Buffer springs (require minimum of 8¼" pit depth)
- Key switch for COP and/or landing controls
- Fire retardant on platform enclosure (required for units installed in fire-rated shafts)
- Egg crate ceiling
- Hoistway doors or frames
- Power operators for hoistway doors
- Delayed action closers for hoistway doors

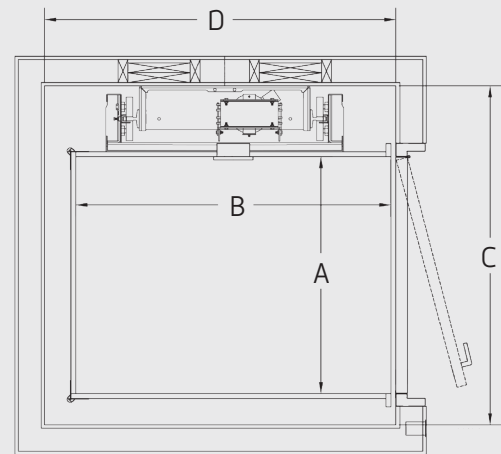

Same Side Configuration

Clear Platform Width A	Clear Platform Length B	Finished Hoistway Width C	Finished Hoistway Length D
36"	48"	50½"	52"
36"	54"	50½"	58"
36"	60"	50½"	64"
42"	60"	56½"	64"
40"	54"	54½"	58"

* Denotes exclusive features

** Standard finish is Brushed Stainless Steel, but multiple finishes available



AccessLiftsandRamps.com • 800-515-5438