

Hydraulic Drive

For Residential Applications

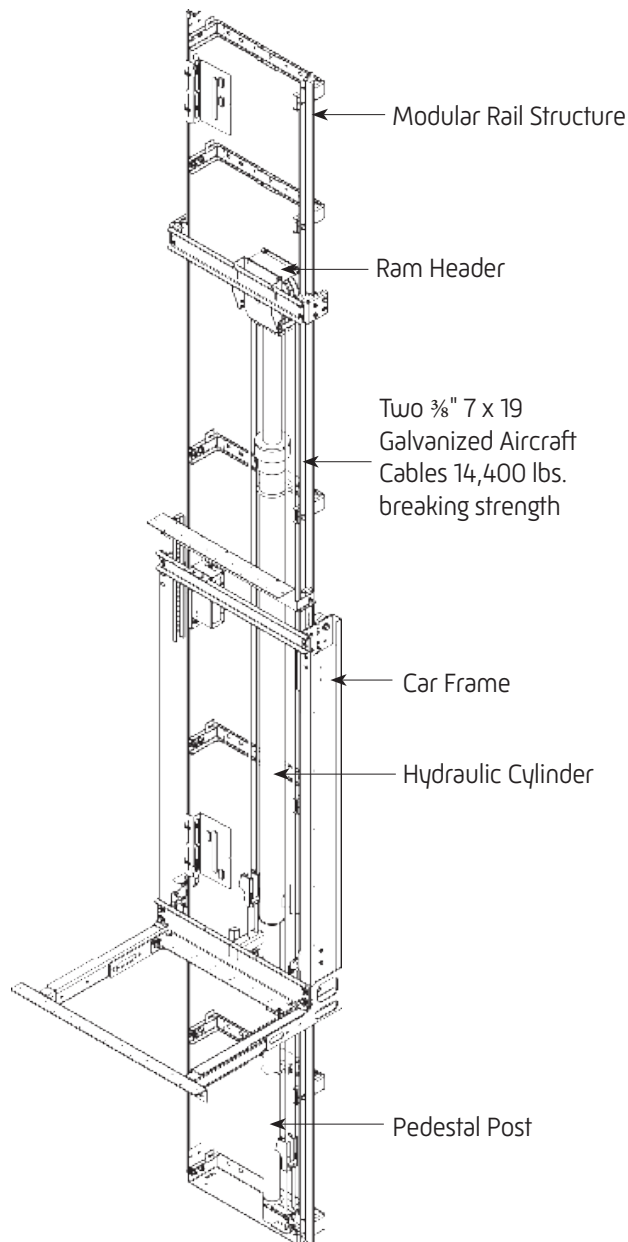

Industry Leading Warranty

- Three-year limited parts warranty
- Extended warranty available

Proudly Made in the U.S.A. 

Smoothest, Quietest Hydraulic Drive on the Market

The Hydraulic Drive is one of the most popular choices for homeowners looking for the quietest ride.

This brochure is intended for INFORMATIONAL PURPOSES ONLY and SHOULD NOT be used for construction.

Standard Features

- Travel: Maximum of 50'0" (minimum 12 inches between stops)
- Speed: 40 fpm
- Rated Capacity: 1,000 lbs.
- Pit Depth: 6" minimum (8 inches preferred)
- Stops: Two
- Opening: Single
- Overhead: Minimum of 7'10" (94 inches) with a 7'0" interior car height
- Warranty: Three-year limited parts

Safety Features

- Slack rope safety device
- Line rupture valve
- Motor controller supply disconnects (located in controller)
- Car light supply disconnects (located in controller)
- Pit stop switch
- Car-top stop switch
- In-car emergency stop switch and alarm
- Safety switch for car gates/doors
- Battery backup emergency car lights and alarm
- Electro-mechanical hoistway door locking devices (doors by others)
- Enhanced gate/bypass monitor
- Unauthorized hoistway entry detection

Controls

- Programmable Logic Controller (PLC)
- Non-selective collective automatic operation
- S.M.A.R.T. system (Self-Monitoring Alert Response Technology)*
- Car Operating Panel (COP) with LED floor position indicator§
- Recessed phone box (phone jack included)§
- Hall stations with call button and LED floor position indicators§
- Automatic car lighting
- Single floor designated car homing
- Uninterruptible Power Supply (UPS) for car lowering and automatic car gate/door operation (if provided) in the event of a power failure*

Car Features

- Car size up to 15 square feet
- 7'0" interior car height
- Birch or Red Oak flat veneer interior walls with flat ceiling
- Matching wood handrail
- Matching wood car sill
- Unfinished plywood floor with sill set for ¾" (flooring by others)
- Two energy-saving recessed LED lights with Black trim rings
- Light Oak, Birch or White 7'0" laminate accordion door

Equipment

- Modular 6¼ lb. T-rail structure
- Car frame assembly
- 208/230 VAC, 60 Hz, 30 amp, single-phase power supply for motor controller
- 120 VAC, 60 Hz, 15 amp, single-phase power supply
- Code-compliant electrical disconnects included*
- Two ¾" 7 x 19 galvanized aircraft cables (14,400 lbs. breaking strength) with wedge rope shackles
- 80 mm diameter piston/102 mm diameter cylinder including ¾ inch reducer bushing
- 3 HP submersed motor with 2-speed valve assembly
- Manual down valve for emergency lowering

Optional Features

- Up to six stops
- Single automatic push-button operation
- Custom car size up to 18 square feet**
- Custom car heights
- Shaker, Recessed or Raised panel car with flat ceiling
- Shaker, Recessed or Raised panel car with matching ceiling
- Four recessed LED lights with Black, White, Polished Brass, Brushed Nickel or Bronze trim rings
- Factory-finished car
- Fixtures including COPs, hall stations, phone boxes and handrails available in:
 - Polished or Blackened Stainless Steel
 - Brushed, Polished or Oil-Rubbed Solid Brass
 - Powder-coated Steel
- COP with integrated keypad phone
- Custom wood interiors
- ¾ inch finished or unfinished installed hardwood car flooring
- Custom sill heights
- Buffer springs (require minimum of 7¾ inch pit depth)
- Key switch for COP and/or hall stations
- Light curtain monitoring the car entrance
- Rated capacity: 750 lbs.
- Symmetry Locking Device (SLD)
- Extended warranty

Car Gate/Door Options

- Symmetry Safety 3-Panel car door
- Two or three speed car door or car and landing doors
- Enterprise collapsible gate
- Dark Oak, Chalk, Antique White, Cherry, Walnut or Black laminate accordion door
- Hardwood veneer accordion door
- Clear or Bronze acrylic panel accordion door
- Automatic car gate/door operator (not available on the Enterprise collapsible gate)
- 1½ hour fire-rated steel door (B-Label)



Visit symmetryelevator.com to view the Residential Elevator Brochure, Design Guide, specification, typical drawings and more

* Symmetry Elevating Solutions exclusive

** May require approval from the local authority having jurisdiction and affect capacity
§ Standard finish is Brushed Stainless Steel, but multiple finishes available