

# Residential Elevator Design Guide

ASME A17.1, Section 5.3

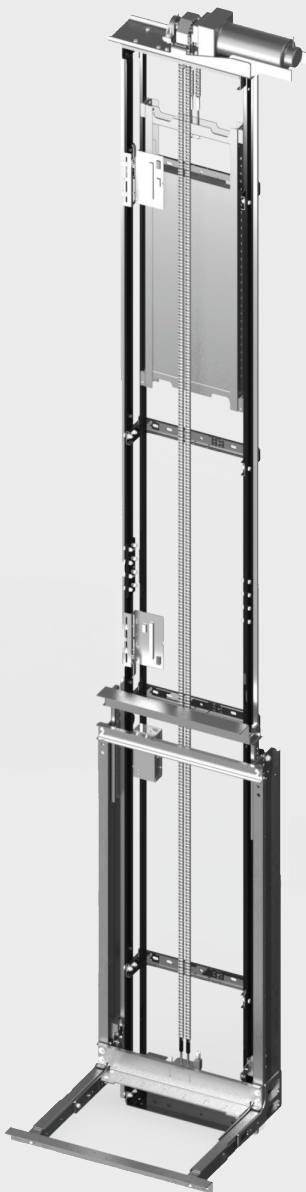

Inline Gear Drive



Hydraulic Drive



Winding Drum Drive

# Table of Contents

About Symmetry Elevating Solutions .....	2
Residential Elevator Safety Notice .....	3
Residential Elevator Drive Systems.....	4
Common Specifications.....	5
Elevator Doors & Gates .....	6-7
Flush Door and/or Frame.....	8
Typical Hoistway Configurations.....	9-13
Hoistway- Typical Rail Backing Construction .....	14
Hoistway-Construction Outline .....	15
Inline Gear Drive-Remote Controller .....	16
Inline Gear Drive-MRL Controller & Access Hatch Detail .....	17
Hydraulic Drive-Machine Rooms.....	18
Winding Drum Drive-Machine Room .....	19

## About Symmetry Elevating Solutions

Symmetry is a beautifully crafted, expertly engineered accessibility-related product line proudly **made in the U.S.A.** at the Bella Elevator LLC manufacturing plant. Promoted and sold by our  exclusive nationwide network of carefully selected Symmetry partners and associates, Symmetry offers residential elevators, vertical platform lifts (VPL), limited use/limited application (LULA) elevators and vertical reciprocating conveyors (VRC).

Strictly following national code guidelines and adhering to local jurisdiction requirements and variances, Symmetry products are ADA and ASME compliant and manufactured to meet the end users' specific needs. Symmetry Elevating Solutions representatives possess a wealth of knowledge and experience and are committed to excellence for the life of the product-before, during and after project completion.

With dealer locations spanning North America, we are equipped to meet the accessibility needs of a wide spectrum of clients, from home and business owners, to schools, municipalities and other governmental entities.

*Please note that this guide is for planning purposes only, applies exclusively to national code, and should not be used for construction. Prior to construction, please contact your local Symmetry Elevating Solutions representative and request a job-specific set of elevator plans to ensure that you obtain the accurate dimensions and requirements for your project.*

*Your representative will also assist you to identify resources to ensure that your project plans will comply with the applicable state and local codes and the permitting authorities.*

# Residential Elevator Safety

## as mandated by national code

### **Securing the space between the hoistway door and the car door/gate**

In 2016, the Safety Code for Elevators and Escalators (ASME A17.1) was updated adopting the new  $\frac{3}{4}$ " x 4" rule. This rule was amended after it was determined that utilizing a standard residential hoistway door, installed under ASME A17.1 (2013 and prior), allows a space between the hoistway door and car gate/door large enough for a child to hide, thus subjecting the child to a potentially unsafe scenario which could result in serious injury if said space is not protected by some other means.

Your Symmetry Elevator is designed and produced to fully comply with this most recent version of the national code.

### **Symmetry Residential Elevators have added security features that protect this space**

All Symmetry Residential Elevators are provided with a standard, enhanced gate/bypass monitor that continuously monitors the elevator control system to detect a scenario where someone may enter the space between the hoistway and the car, without ever entering the car. The enhanced gate/bypass monitor will keep the elevator from leaving the landing should it detect the aforementioned event.

### **Final hoistway door location following contractor installation is the key**

Your local jurisdiction may not require the hoistway door installation, performed by your local contractor, to meet the latest requirements; however, we highly recommend that all elevator installations comply with the ASME A17.1 (2016 and newer) code, or more stringent version, in regard to this gap once the installation is complete and the elevator inspected.

While this is highly recommended, but out of our control, should you live in a jurisdiction that still enforces the ASME A17.1 (2013 and prior) code, allowing for a larger gap, your elevator will also be equipped with a light curtain that projects a crisscross pattern of 94 beams to keep the elevator from leaving the landing should an obstruction be detected.

Your safety is our number one priority, thus rest assured that regardless of the version of Elevator and Escalator Safety Code enforced in your jurisdiction, your Symmetry Residential Elevator safely protects the space between the hoistway door and car gate/door.

# Elevator Drive Systems

## Inline Gear Drive System

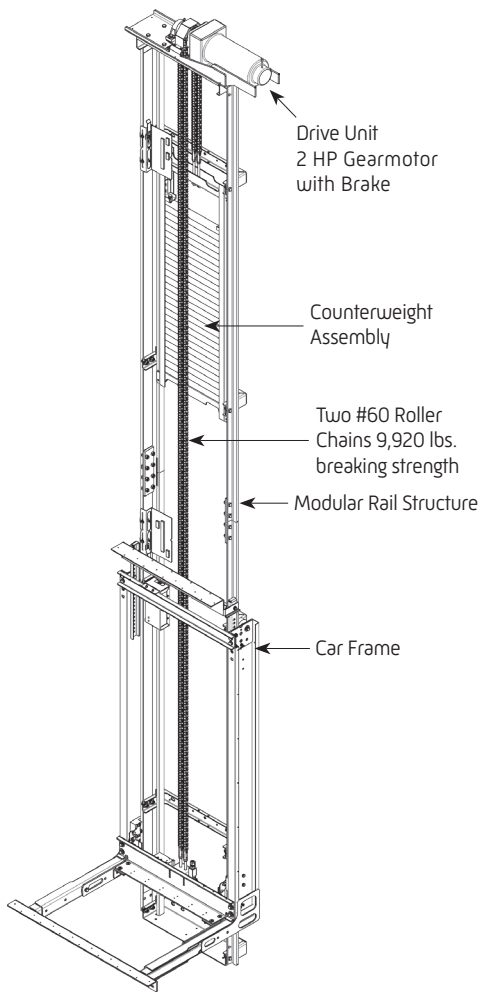

### Standard Features

- Overhead: Minimum of 8'0" [96 inches] with remote controller; minimum of 9'0" with controller in hoistway with a 7'0" interior car height

### Equipment

- 208/230 VAC, 60 Hz, 20 amp, single-phase power supply for motor controller
- Two #60 roller chains [9,920 lbs. breaking strength]
- Inverter-controlled variable speed Inline Gear Drive unit with counterweight and 2 HP motor
- Manual lowering device

### Safety Features

- Slack chain safety device
- Two upper and one lower final limits
- Machine stop switch

## Hydraulic Drive System

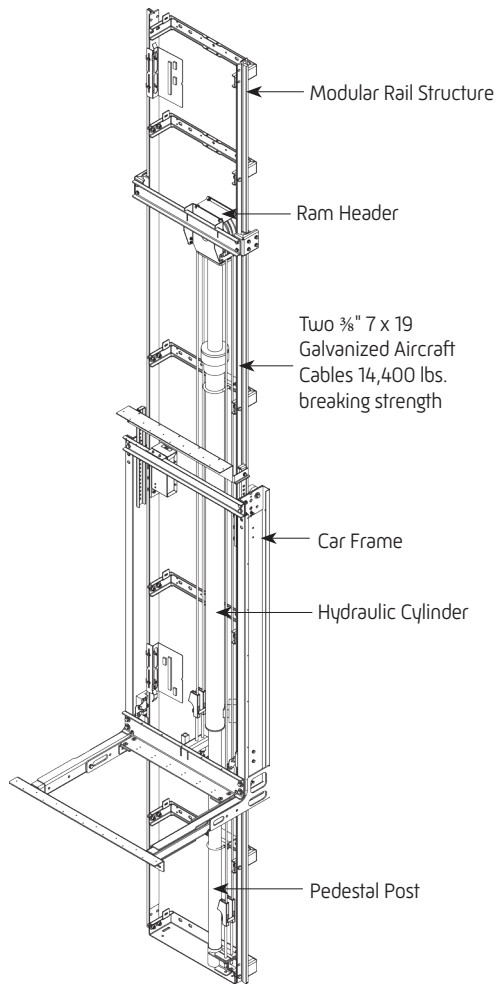

### Standard Features

- Overhead: Minimum of 7'10" [94 inches] with a 7'0" interior car height

### Equipment

- 208/230 VAC, 60 Hz, 30 amp, single-phase power supply for motor controller
- Two 3/8" 7 x 19 galvanized aircraft cables [14,400 lbs. breaking strength] with wedge rope shackles
- 80 mm diameter piston/102 mm diameter cylinder including 3/4 inch reducer bushing
- 3 HP submersed motor with 2-speed valve assembly
- Manual down valve for emergency lowering

### Safety Features

- Slack rope safety device
- Line rupture valve

## Winding Drum Drive System

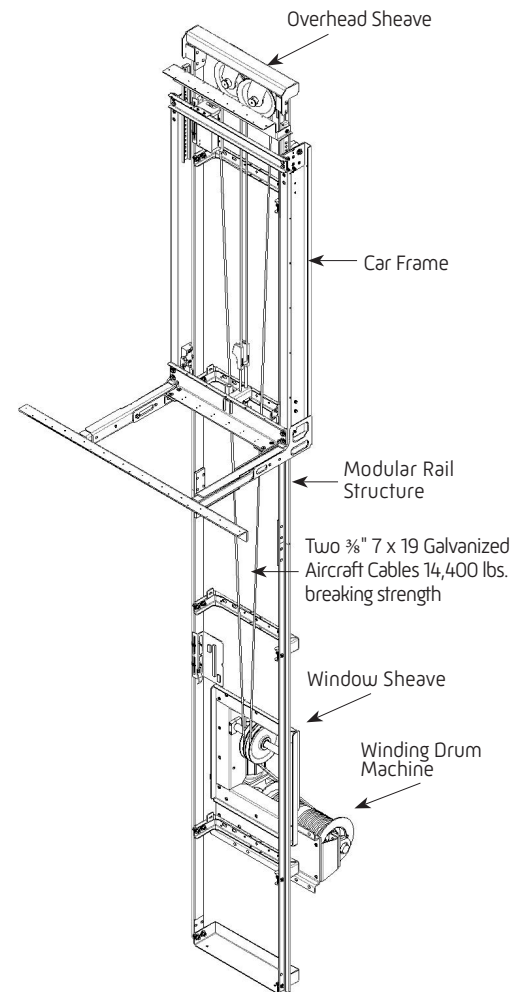

### Standard Features

- Overhead: Minimum of 7'10" [94 inches] with a 7'0" interior car height

### Equipment

- 208/230 VAC, 60 Hz, 30 amp, single-phase power supply for motor controller
- Two 3/8" 7 x 19 galvanized aircraft cables [14,400 lbs. breaking strength] with wedge rope shackles
- Inverter-controlled variable speed Winding Drum Drive unit and 3 HP motor
- Manual lowering device

### Safety Features

- Slack rope safety device
- Two upper and one lower final limits

# Common Specifications

## For residential elevators

### Standard Features

- Travel: Maximum of 50'0" (minimum 12 inches between stops)
- Speed: 40 fpm
- Rated Capacity: 1,000 lbs.
- Pit Depth: 6 inches minimum (8 inches preferred)
- Stops: Two
- Opening: Single
- Warranty: Three-year limited parts

### Safety Features

- Motor controller supply disconnects (located in controller)
- Car light supply disconnects (located in controller)
- Pit stop switch
- Car-top stop switch
- In-car emergency stop switch and alarm
- Safety switch for car gates/doors
- Battery backup emergency car lights and alarm
- Electro-mechanical hoistway door locking devices (doors by others)
- Enhanced gate/bypass monitor
- Unauthorized hoistway entry detection

### Controls

- Programmable Logic Controller (PLC)
- Non-selective collective automatic operation
- S.M.A.R.T. system (Self-Monitoring Alert Response Technology)\*
- Car Operating Panel (COP) with LED floor position indicator§
- Recessed phone box (phone jack included)§
- Hall stations with call button and LED floor position indicator§
- Automatic car lighting
- Single floor designated car homing
- Uninterruptible Power Supply (UPS) for car lowering and automatic car gate/door operation (if provided) in the event of a power failure\*

### Car Features

- Car size up to 15 square feet
- 7'0" interior car height
- Birch or Red Oak flat veneer interior walls with flat ceiling\*
- Matching wood handrail
- Matching wood car sill
- Unfinished plywood floor with sill set for ¾ inch (flooring by others)
- Two energy-saving recessed LED lights with Black trim rings
- Light Oak, Birch or White 7'0" laminate accordion door

### Equipment

- Modular 6¼ lb. T-rail structure
- Car frame assembly
- Power supply for motor controller (see each drive for specifics)
- 120 VAC, 60 Hz, 15 amp, single-phase power supply
- Code-compliant electrical disconnects included\*

### Optional Features

- Up to six stops
- Single automatic push-button operation
- Custom car size up to 18 square feet\*\*
- Custom car heights
- Shaker, Recessed or Raised panel car with flat ceiling
- Shaker, Recessed or Raised panel car with matching ceiling
- Four recessed LED lights with Black, White, Polished Brass, Brushed Nickel or Bronze trim rings
- Factory-finished car
- Fixtures including COPs, hall stations, phone boxes and handrails available in:
  - Polished or Blackened Stainless Steel
  - Brushed, Polished or Oil-Rubbed Solid Brass
  - Powder-coated Steel
- COP with integrated keypad phone
- Custom wood interiors
- ¾ inch finished or unfinished installed hardwood car flooring
- Custom sill heights
- Buffer springs (require minimum of 7¾ inch pit depth)
- Key switch for COP and/or hall stations
- Rated capacity: 750 lbs.
- Light curtain monitoring the car entrance
- Symmetry Locking Device (SLD)
- Extended warranty

### Car Gate/Door Options

- Symmetry Safety 3-Panel car door
- Two or three speed car door or car and landing doors
- Enterprise collapsible gate
- Dark Oak, Chalk, Antique White, Cherry, Walnut or Black laminate accordion door
- Hardwood veneer accordion door
- Clear or Bronze acrylic panel accordion door
- Automatic car gate/door operator (not available on the Enterprise collapsible gate)
- 1½ hour fire-rated steel door (B-Label)

\* Denotes exclusive features

\*\* May require approval from the local authority having jurisdiction and affect capacity

§ Standard finish is Brushed Stainless Steel, but multiple finishes available

# Elevator Doors & Gates

## Symmetry Safety 3-Panel Car Door



*Our exclusive Symmetry Safety 3-Panel Door is one of the safest residential elevator car doors on the market. Shown in Brushed Stainless Steel with vision panels.*

### Standard Features

- Manual Car Door Operation: The trailing panel of the car door measures 2 inches from edge of the car sill and is designed to fit within requirements of the  $\frac{3}{4}$ " x 4" rule, with maximum running clearance and maximum hoistway door setback of  $\frac{3}{4}$  inch
- Height of Opening: 7'0"
- Car Door Opening: 33 inches clear opening (fits in a "typical" hoistway with a 36 inch wide car)
- Standard Finish: Black

### Options

- Light Curtain: Standard as secondary protective device if installed under ASME A17.1 (2013 and prior); optional if installed under ASME A17.1 (2016 and newer)
- Power Car Door Operation
- Height of Opening: 7'11"; custom heights available
- Car Door Opening: 36 inches clear opening (fits in a "typical" hoistway with a 40 inch wide car)
- Vision Panels: Available with Clear or Bronze acrylic
- Car Door: Available in Stainless Steel or powder-coated steel

## Enterprise Collapsible Gate



*The Enterprise Collapsible Gate is always designed and manufactured to comply with current codes. Shown in Black.*

### Standard Features

- Nylon "Quiet Glide" wheels for smooth operation when opening and closing gate
- Low profile handles
- Rejects a ball 3 inches in diameter
- Every third vertical member guided at the top
- Every vertical member guided at the bottom
- Standard Finish: Black

### Options

- Light Curtain: Standard as a secondary protective device if installed under ASME A17.1 (2013 and prior); optional if installed under ASME A17.1 (2016 and newer)
- Car Gates: Available in Stainless Steel (brushed or polished) or powder-coated steel
- Available Configurations: Classic, Pearl and Diamond and Pearl

# Elevator Doors & Gates

## Accordion Door



The Accordion Door is one of our most popular door choices. Shown in Antique White with vision panels.

### Standard Features

- Laminate Panels: Available in Light Oak, Birch or White
- Height of Opening: 7'0" or 7'11"
- Mechanical Locking Hinging: Meets the deflection requirements of ASME A17.1 (2016 and newer)\*

### Options

- Light Curtain: Standard as a secondary protective device if installed under ASME A17.1 (2013 and prior); optional if installed under ASME A17.1 (2016 and newer)
- Automatic car door operator
- Additional Panel Options:
  - Laminate panels in Dark Oak, Chalk, Antique White, Cherry, Walnut or Black
  - Unfinished or finished matching hardwood veneer
  - Clear or Bronze acrylic
  - Solid or Perforated aluminum
- Height of Opening: From 6'8" up to 8'0"
- Custom sizes available

NOTE: Accordion doors will have Bronze hardware except on White, Chalk or Antique White doors. Clear acrylic accordion doors will typically have Clear hardware when Stainless Steel or Black fixtures are provided.

\* ASME A17.1 (2016 and newer) installations require a ¼ inch maximum hoistway door setback

## Two or Three Speed Doors



Automatic commercial-style doors optimize ease of use for passengers. Car door only or car and landing door packages available. Three Speed Car Door shown in Brushed Stainless Steel.

### Standard Features

- Light Curtain
- Power-operated
- Clear Opening Width for Three Speed: 31½" or 35½"
- Clear Opening Width for Two Speed: 35½"
- Clear Heights: 78¾", 84⅝" or 94½"
- Standard Finish: Beige

### Overhead Requirements

- Two Speed Doors
  - Car and Landing Doors: Clear height plus 19¼"
  - Car Door Only: Clear height plus 18¼"
- Three Speed Doors
  - Car and Landing Doors/Car Door Only: 101" (only available for clear height of 78¾")

### Options

- Framed Glass Panels: Available with clear safety glass, standard finish for framed glass panels is Black
- Car Doors: Available in Brushed Stainless or powder-coated steel

# Flush Frame & Locking Devices



Flush Frame with Symmetry Locking Device (SLD)  
[Door by others]

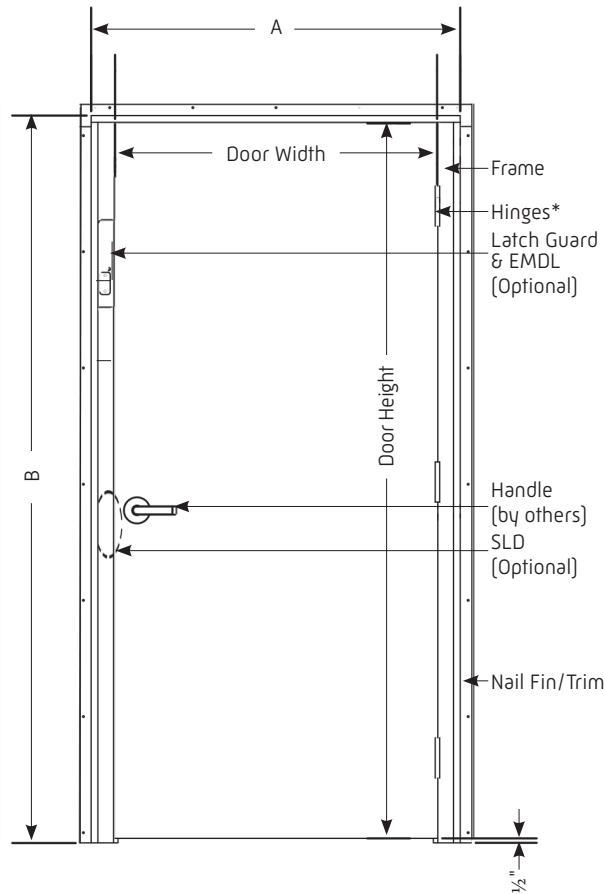

Flush Frame with EMDL and Latch Guard  
[Door by others]



SLD Lock Plate



SLD Lock Body

36" Wide x 80" Tall Door [by others]						
Lock	Frame Size			Rough Opening		
	A		B	A		B
EMDL	41¼"	x	81⅜"	42¼"	x	81⅞"
SLD	38¼"	x	81⅜"	39¼"	x	81⅞"
36" Wide x 95" Tall Door [by others]						
Lock	Frame Size			Rough Opening		
	A		B	A		B
EMDL	41¼"	x	96⅜"	42¼"	x	96⅞"
SLD	38¼"	x	96⅜"	39¼"	x	96⅞"



Latch Guard  
[Exterior View]



Electro-Mechanical Interlock (EMDL)

## Notes:

- 1) The frame is suitable for installation in masonry or wood frame construction
- 2) The frame is installed with the door flush to the inside of the hoistway
- 3) The interior hoistway wall should be finished up to the rough opening
- 4) Available as a frame only

\*Hinges by others



# Typical Hoistway Configurations

All hoistway dimensions reference interior dimensions—finished wall to finished wall

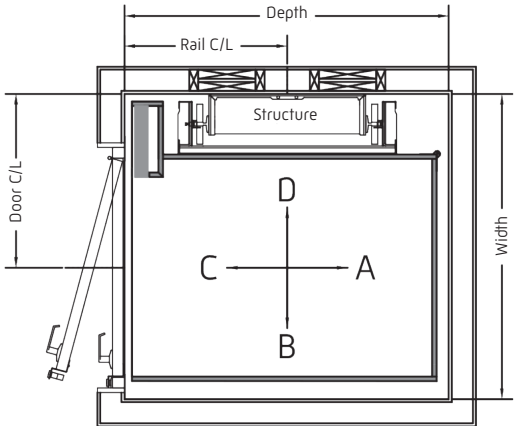

**Single Opening**  
 Rail Left, Right-Hand Door (shown)  
 Rail Right, Left-Hand Door (opposite)

Car Gate/Door	Car Size	Width	Depth	Rail C/L	Door C/L	Clear Opening
Accordion or Collapsible (2)	36X48	50½"	54¼"	27½"	28¾"	33½"
	36X60	50½"	66¼"	33½"	28¾"	33½"
	40X54	54½"	60¼"	32"	32¾"	33½" (3)
Symmetry Safety 3-Panel (shown)	36X48	52"	55"	31"	30¼"	33"
	36X60	52"	67"	33½"	30¼"	33"
	40X54	54½"	61"	32"	32¾"	33" (3)

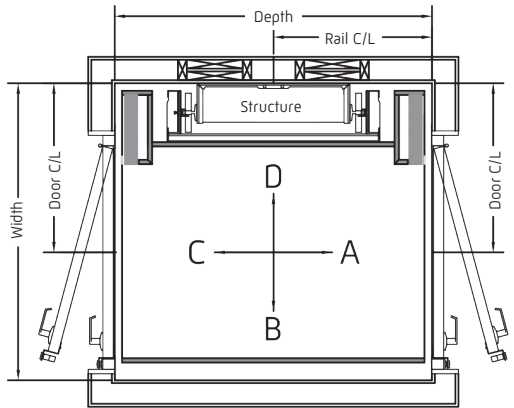

**Opposite Opening**  
 Rail Right, Left-Hand Door, Right-Hand Door  
 Rail Left, Right-Hand Door, Left-Hand Door

Car Gate/Door	Car Size	Width	Depth	Rail C/L	Door C/L	Clear Opening
Accordion or Collapsible (2)	36X48	50½"	54"	27"	28¾"	33½"
	36X60	50½"	66"	33"	28¾"	33½"
	40X54	54½"	60"	30"	32¾"	33½" (3)
Symmetry Safety 3-Panel (shown)	36X54	52"	61¾"	31"	30¼"	33"
	36X60	52"	67¾"	34"	30¼"	33"
	40X54	54½"	61¾"	31"	32¾"	33" (3)

- (1) Inline Gear Drive motor extends into the access hatch
- (2) Collapsible gates will have a clear opening approximately 1" less than shown
- (3) 36" clear opening available—door centerlines may change
- (4) Door centerlines shown with 2'8" doors  
 Door centerlines apply to 3'0" doors, except where otherwise noted  
 Car sizes over 15 square feet may require approval from the local authority having jurisdiction

# Typical Hoistway Configurations

All hoistway dimensions reference interior dimensions—finished wall to finished wall

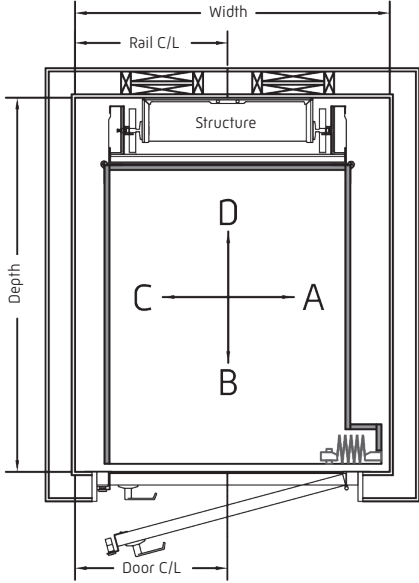

## Single Opening

Rail Front, Left-Hand Door (shown)  
Rail Front, Right-Hand Door (opposite)

Car Gate/Door	Car Size	Width	Depth	Rail C/L	Door C/L	Clear Opening
Accordion or Collapsible (2) (shown)	48X36	48"	62¼"	22" (1)	23¼"	32½"
	60X36	48"	74¼"	22" (1)	23¼"	32½"
	54X40	48"	68¼"	24" (1)	21¾"	32½"
Symmetry Safety 3-Panel	48X36	52¼"	63⅞"	22" (1)	21¾"	33"
	60X36	52¼"	75⅞"	22" (1)	21¾"	33"
	54X40	52¼"	69⅞"	24½"	21¾"	33"

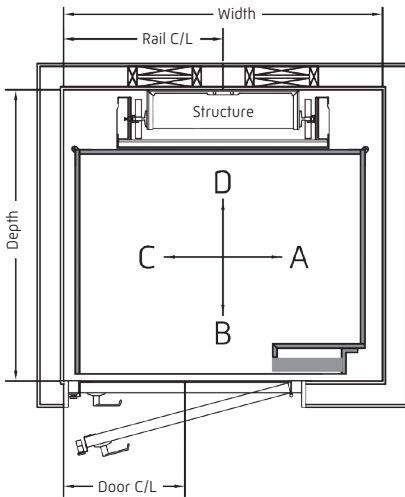

## Single Opening

Rail Front, Left-Hand Door (shown)  
Rail Front, Right-Hand Door (opposite)

Car Gate/Door	Car Size	Width	Depth	Rail C/L	Door C/L	Clear Opening
Accordion or Collapsible (2)	36X48	55"	50¼"	27½"	21¾"	33½" (3)
	36X60	67"	50¼"	33½"	21¾"	33½" (3)
	40X54	61"	54¼"	30½"	21¾"	33½" (3)
Symmetry Safety 3-Panel (shown)	36X48	55"	51⅞"	27½"	21¾"	33"
	36X60	67"	51⅞"	33½"	21¾"	33" (3)
	40X54	61"	55⅞"	30½"	21¾"	33" (3)

- (1) Inline Gear Drive motor extends into the access hatch
- (2) Collapsible gates will have a clear opening approximately 1" less than shown
- (3) 36" clear opening available—door centerlines may change
- (4) Door centerlines shown with 2'8" doors  
Door centerlines apply to 3'0" doors, except where otherwise noted  
Car sizes over 15 square feet may require approval from the local authority having jurisdiction

# Typical Hoistway Configurations

All hoistway dimensions reference interior dimensions—finished wall to finished wall

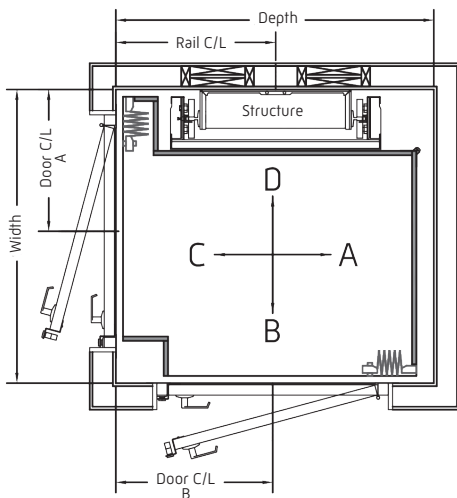

## 90° Opening

Rail Left, Right-Hand Door, Left-Hand Door or  
 Rail Front, Left-Hand Door, Right-Hand Door (shown)  
 Rail Right, Left-Hand Door, Right-Hand Door or  
 Rail Front, Right-Hand Door, Left-Hand Door (opposite)

Car Gate/Door	Car Size	Width	Depth	Rail C/L	Door C/L A	Clear Opening A	Door C/L B	Clear Opening B
Accordion or Collapsible (2) (shown)	36X48	50¼"	54¾"	31"	24¼"	31"	26"	33½"
	36X60	50¼"	66¾"	33½"	24¼"	31"	38"	33½" [3]
	40X54	54¼"	60¾"	32"	28¼"	33½"	31⅞"	33½" [3]
Symmetry Safety 3-Panel	40X48	55⅝"	55⅝"	31"	30⅝"	33"	25⅞"	33"
	40X54	55⅝"	61⅝"	32"	30⅝"	33"	31⅞"	33" [3]

## 90° Opening

Rail Right, Right-Hand Door, Left-Hand Door or  
 Rail Front, Left-Hand Door, Right-Hand Door (shown)  
 Rail Left, Left-Hand Door, Right-Hand Door or  
 Rail Front, Right-Hand Door, Left-Hand Door (opposite)

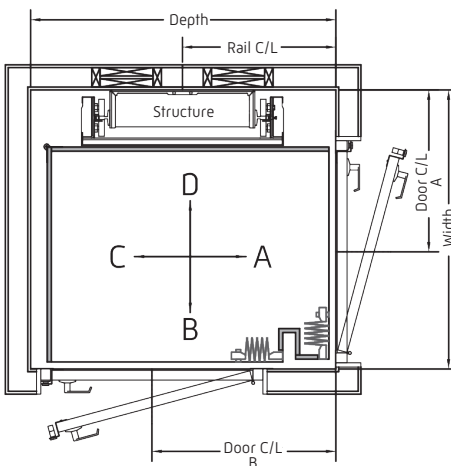

Car Gate/Door	Car Size	Width	Depth	Rail C/L	Door C/L A	Clear Opening A	Door C/L B	Clear Opening B
Accordion or Collapsible (2) (shown)	36X48	50¼"	54¾"	27½"	29¼"	28½"	33"	33½"
	36X60	50¼"	66¾"	33½"	29¼"	28½"	45"	33½" [3]
	40X54	54¼"	60¾"	32"	29¼"	32½"	39"	33½" [3]
Symmetry Safety 3-Panel	44X48	59⅝"	55⅝"	28"	29¼"	33"	33⅞"	33"
	44X54	59⅝"	61⅝"	31"	29¼"	33"	39⅞"	33" [3]

[1] Inline Gear Drive motor extends into the access hatch

[2] Collapsible gates will have a clear opening approximately 1" less than shown

[3] 36" clear opening available—door centerlines may change

[4] Door centerlines shown with 2'8" doors

Door centerlines apply to 3'0" doors, except where otherwise noted

Car sizes over 15 square feet may require approval from the local authority having jurisdiction

# Typical Hoistway Configurations

All hoistway dimensions reference interior dimensions—finished wall to finished wall

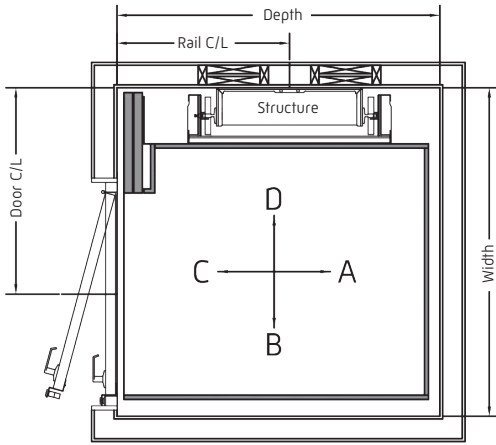

## Single Opening

Rail Left, Right-Hand Door (shown)  
Rail Right, Left-Hand Door (opposite)

Car Gate/Door	Car Size	Width	Depth	Rail C/L	Door C/L	Clear Opening
Two Speed Car Doors (shown)	44X48	59"	57½"	31"	37¼"	35½"
	44X54	59"	63½"	32"	37¼"	35½"
Three Speed Car Doors	36X48	50½"	58¼"	31½"	30¾"	31½" (4)
	36X60	50½"	70¼"	35"	30¾"	31½" (4)
	38X48	53½"	58¼"	31½"	31¾"	35½"
	38X60	53½"	70¼"	35"	31¾"	35½"
	40X54	54½"	64¼"	32"	32¾"	35½"

## Opposite Opening

Rail Left, Right-Hand Door, Left-Hand Door  
Rail Right, Left-Hand Door, Right-Hand Door

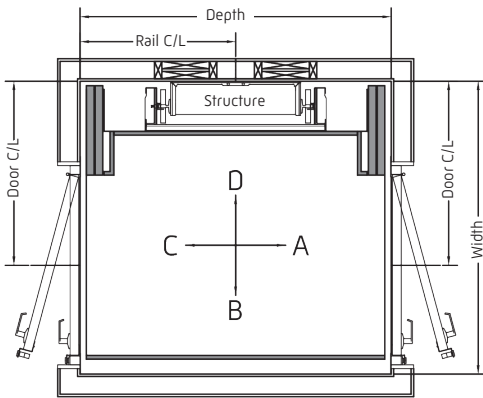

Car Gate/Door	Car Size	Width	Depth	Rail C/L	Door C/L	Clear Opening
Two Speed Car Doors (shown)	44X48	59"	61½"	31"	37¼"	35½"
	44X54	59"	67½"	34"	37¼"	35½"
Three Speed Car Doors	36X48	50½"	63"	32"	30¾"	31½" (4)
	36X60	50½"	75"	38"	30¾"	31½" (4)
	38X48	53½"	63"	32"	31¾"	35½"
	38X60	53½"	75"	38"	31¾"	35½"
	40X54	54½"	69"	35"	32¾"	35½"

(1) Inline Gear Drive motor extends into the access hatch

(2) Collapsible gates will have a clear opening approximately 1" less than shown

(3) 36" clear opening available—door centerlines may change

(4) Door centerlines shown with 2'8" doors

Door centerlines apply to 3'0" doors, except where otherwise noted

Car sizes over 15 square feet may require approval from the local authority having jurisdiction

# Typical Hoistway Configurations

All hoistway dimensions reference interior dimensions—finished wall to finished wall

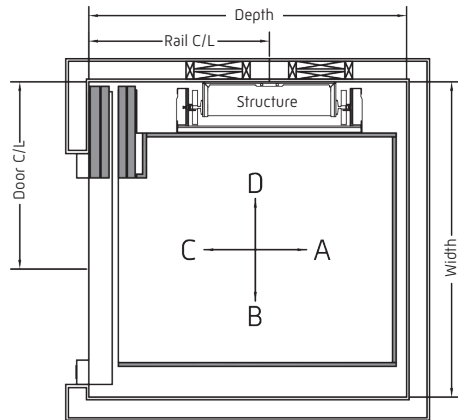

## Single Opening

Rail Left, Right-Hand Door (shown)

Rail Right, Left-Hand Door (opposite)

Car Gate/Door	Car Size	Width	Depth	Rail C/L	Door C/L	Clear Opening
Two Speed Car Doors (shown)	44X48	62"	62"	35½"	37¾"	35½"
	44X54	62"	68"	37"	37¾"	35½"
Three Speed Car Doors	36X48	52¾"	63"	36½"	30½"	31½" (4)
	36X60	52¾"	75"	42½"	30½"	31½" (4)
	38X48	55¾"	63"	36½"	31½"	35½"
	38X60	55¾"	75"	42"	31½"	35½"
	40X54	56¾"	69"	39½"	32½"	35½"

## Opposite Opening

Rail Left, Right-Hand Door, Left-Hand Door

Rail Right, Left-Hand Door, Right-Hand Door

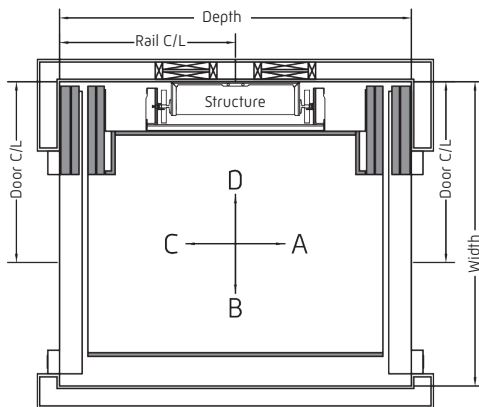

Car Gate/Door	Car Size	Width	Depth	Rail C/L	Door C/L	Clear Opening
Two Speed Car Doors (shown)	44X48	62"	70½"	35½"	37¾"	35½"
	44X54	62"	76½"	38½"	37¾"	35½"
Three Speed Car Doors	36X48	52¾"	72¾"	36½"	30½"	31½"
	36X60	52¾"	84¾"	42½"	30½"	31½"
	38X48	55¾"	72¾"	36½"	31½"	35½"
	38X60	55¾"	84¾"	42½"	31½"	35½"
	40X54	56¾"	78¾"	39½"	32½"	35½"

(1) Inline Gear Drive motor extends into the access hatch

(2) Collapsible gates will have a clear opening approximately 1" less than shown

(3) 36" clear opening available—door centerlines may change

(4) Door centerlines shown with 2'8" doors

Door centerlines apply to 3'0" doors, except where otherwise noted

Car sizes over 15 square feet may require approval from the local authority having jurisdiction

# Hoistway

## Typical rail backing construction

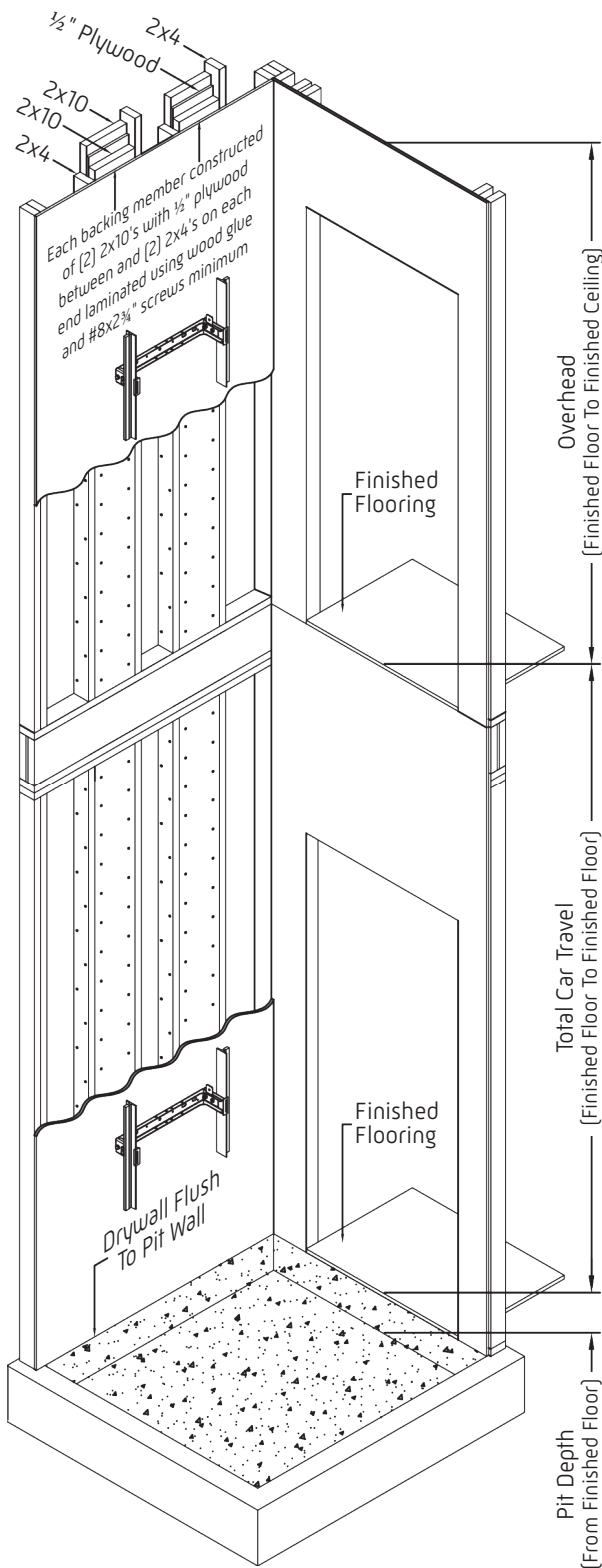

Each backing member constructed of (2) 2 x 10's with 1/2 inch plywood between and (2) 2 x 4's on each end laminated using wood glue and #8 x 2 3/4" screws, 2 per row minimum, spaced on 6 inch vertical centers.

Please note that Winding Drum Drives with greater than 30 feet of travel require 2 x 12's in lieu of the 2 x 10's and the centerline spacing increases from 10 inches to 12 inches.

Installing 1/2 inch plywood behind the drywall will improve the sound deadening and strengthen the hoistway.

The specified loads are based on the worst case load condition of 1,000 lb. capacity, 925 lb. car and frame weight and a 60 inch cantilever car.

The assumptions made relative to the standard backing arrangement are a maximum span of 10 feet, a minimum wood modulus of elasticity of  $1.95 \times 10^6$  psi (Douglas Fir) and stiffening factor from the elevator's rail structure based on the bracket spacing.

If the backer span exceeds 10 feet or if the backing construction and/or materials are not as specified, please consult a structural engineer.

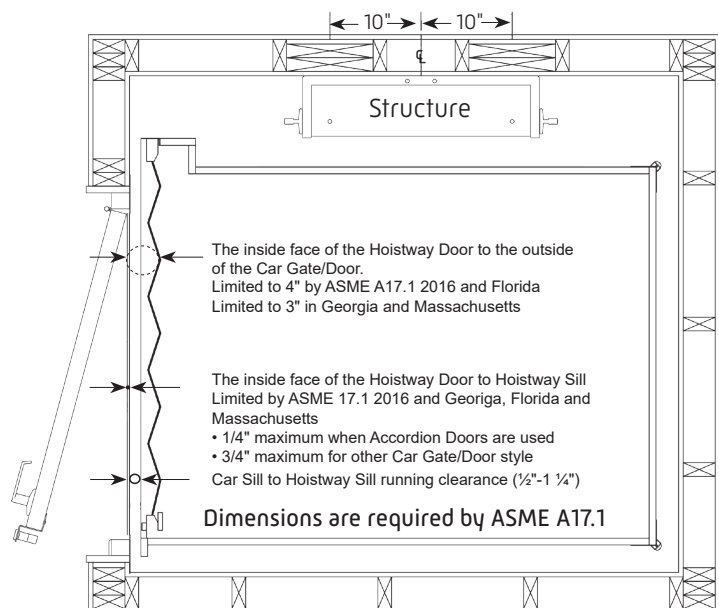
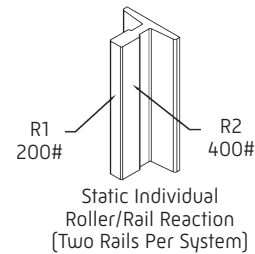

Typical Framework with Drywall Construction

# Hoistway

## Construction outline

### Rail Backing & General Hoistway

- Provide adequate rail backing per drawings. For vertical spans between floor systems that exceed 10'0", please consult a structural engineer. The wall must be capable of supporting the static roller/rail loads without deflecting more than ¼ inch.
- The hoistway must be constructed square and plumb within ¼ inch tolerance throughout.
- The hoistway must be free of any obstructions not related to the operation of the elevator. (i.e. sprinklers, pipes, ducts, etc.)
- The structure of the hoistway must allow for installation of a chain hoist to transfer materials during installation.
- Provide hoistway doors that are a minimum of 3'0" x 6'8" and solid core construction.

### Pit Floor

- Provide a pit floor at a minimum of 6 inches (8 inches preferred) from the top of the finished floor to the highest point in the pit. (Note: Three speed car and landing doors require a minimum of 10 inches pit depth.)
- Provide a pit floor capable of withstanding the impact load of 6,766 lbs. and the static load of 3,840 lbs.

### Overhead

- Inline Gear Drive
  - Provide a minimum overhead of 8'0" for a 7'0" interior car height with a remote mounted controller.
  - Provide a minimum overhead of 9'0" for a 7'0" interior car height with an in-the-shaft controller.
- Hydraulic or Winding Drum Drive
  - Provide a minimum overhead of 7'10" for a 7'0" interior car height.
- If a Shaker, Recessed or Raised panel ceiling is used, an additional inch of overhead is required.

### Drive-Specific Items

- Inline Gear Drive
  - Provide a minimum 8" x 8" access hatch at or near the top of the hoistway for manual lowering. (See Access Hatch Detail on page 17.)
- Winding Drum Drive
  - Provide a framed window between the machine room and the hoistway for passing of the suspension means. (See page 19.)

*Please note that this guide is for planning purposes only, applies exclusively to national code, and should not be used for construction. Prior to construction, please contact your local Symmetry Elevating Solutions representative and request a job-specific set of elevator plans to ensure that you obtain the accurate dimensions and requirements for your project.*

*Your representative will also assist you to identify resources to ensure that your project plans will comply with the applicable state and local codes and the permitting authorities.*

# Inline Gear Drive

## Remote controller

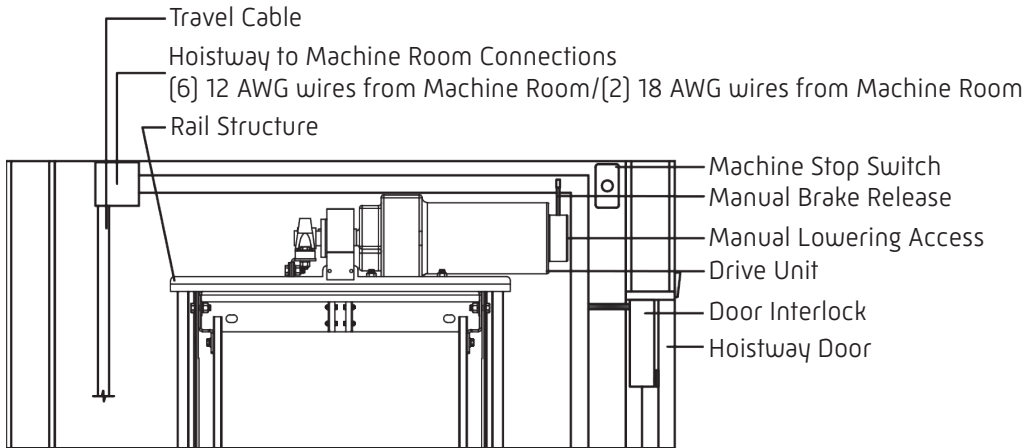

### Notes:

- 1) The minimum overhead clearance as measured from the top of the upper landing sill to the bottom of the shaft ceiling is 8'0" for a standard 7'0" car.
- 2) This layout is shown for manual lowering access at the top right of the view. The drive unit can be mounted opposite to accommodate access.

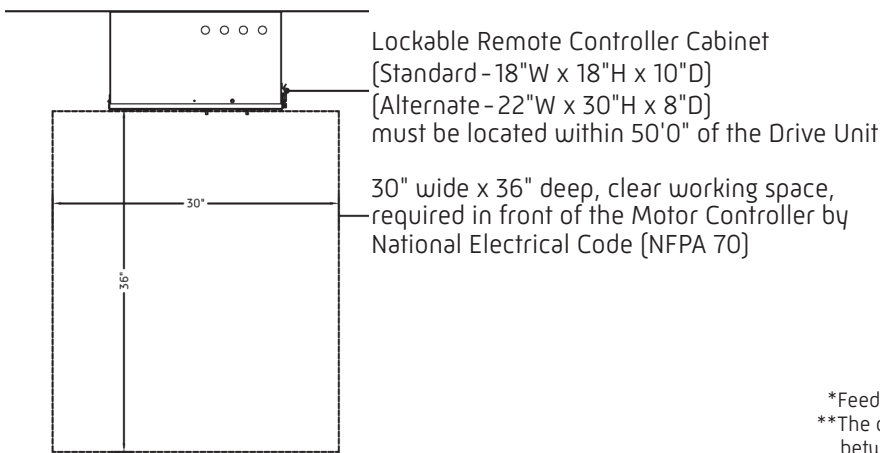
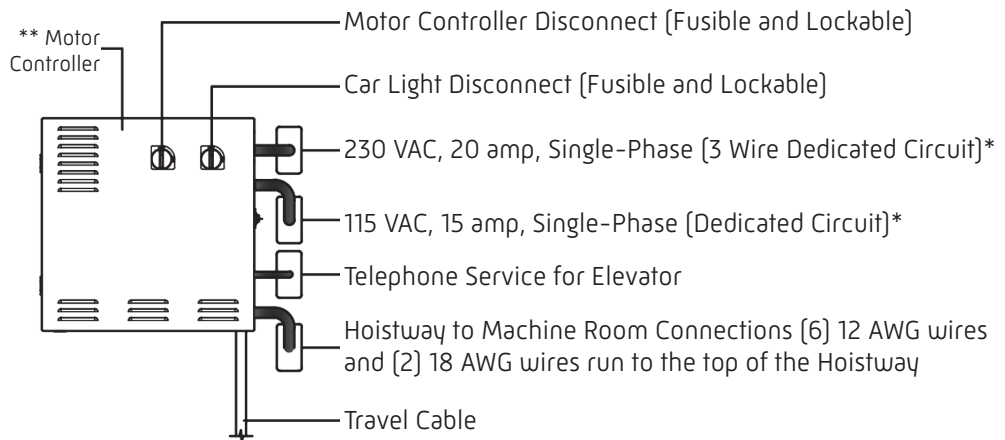

\*Feeding breaker must not be a GFCI  
 \*\*The control space temperature must be maintained between 32°F and 80°F.



# Inline Gear Drive

## MRL controller and access hatch detail

### MRL Controller

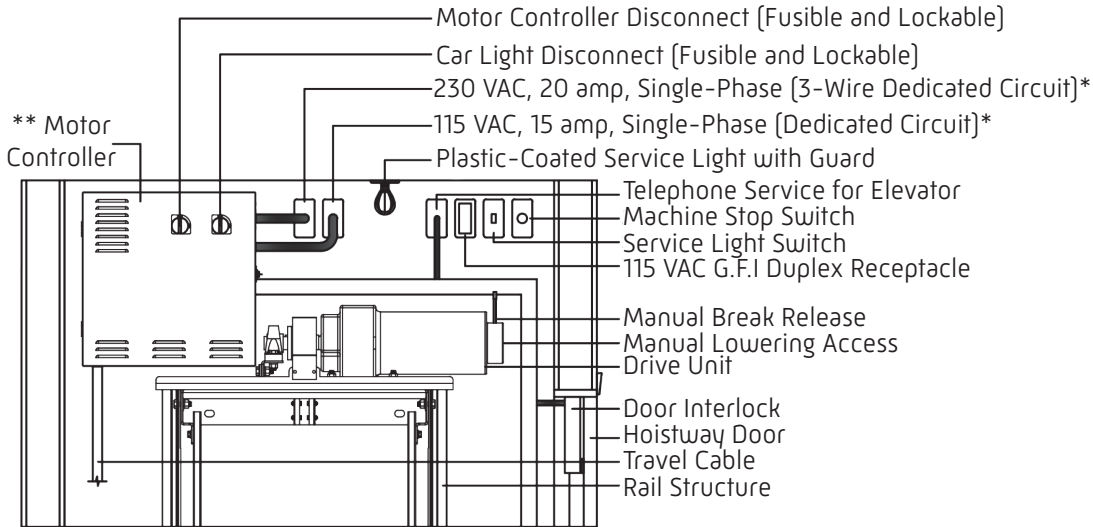

### Notes:

- 1) The minimum overhead clearance as measured from the top of the upper landing sill to the bottom of the shaft ceiling is 9'0" for a standard 7'0" car.
- 2) This layout is shown for manual lowering access at the top right of the view. The drive unit can be mounted opposite to accommodate access.
- 3) The MRL Controller option is not available in all jurisdictions, please contact your local Symmetry Elevating Solutions representative or local authority to confirm acceptance.

\*Feeding breaker must not be a GFCI

\*\*The control space temperature must be maintained between 32°F and 80°F.

### Access Hatch Detail

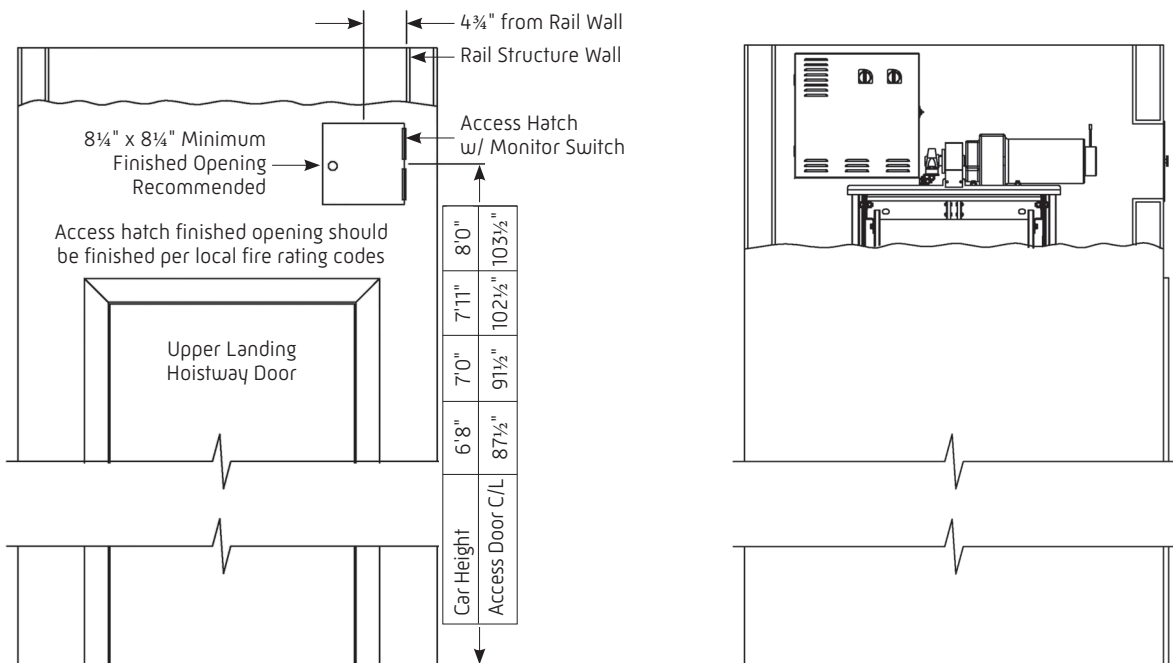

# Hydraulic Drive Machine rooms

## Standard Machine Room

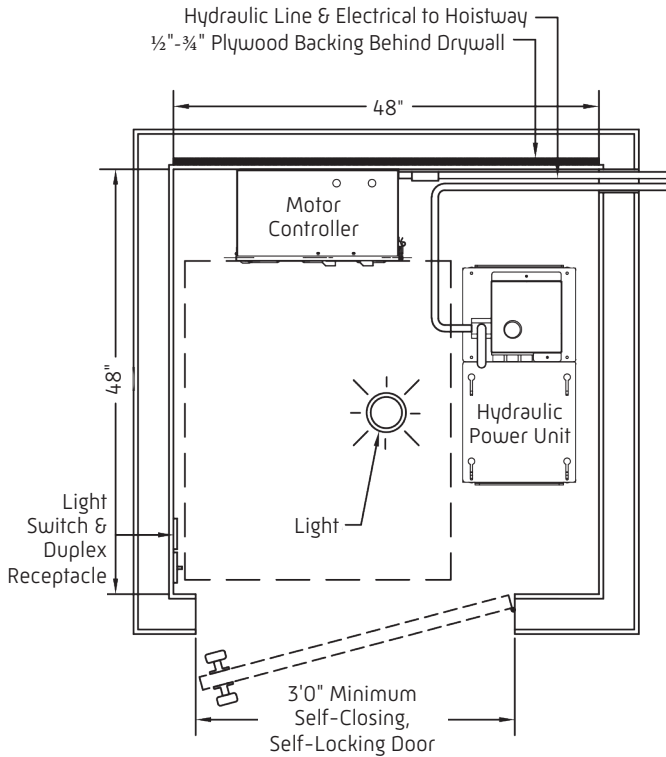

## Compact Machine Room

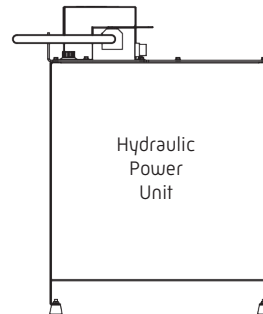
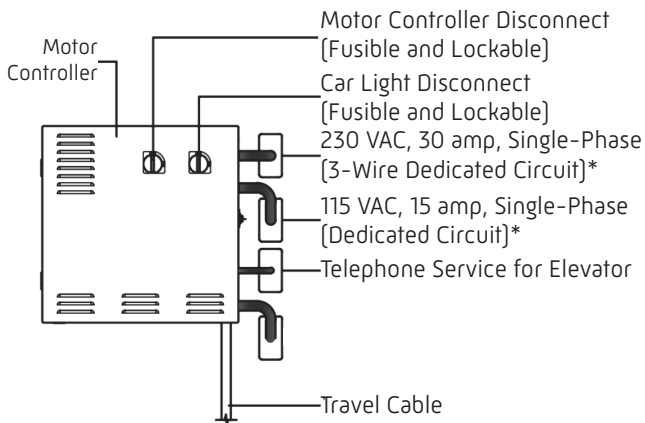
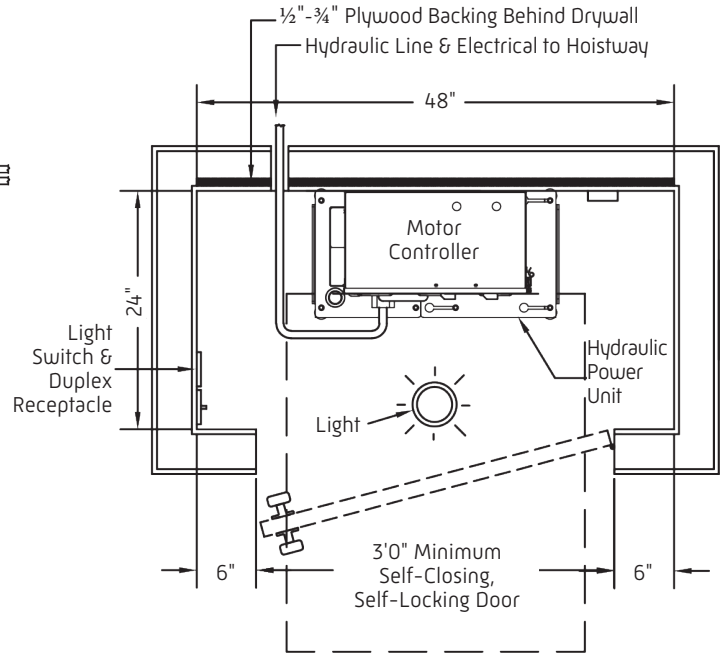

**Motor Controller**  
Standard - 18"W x 18"H x 10"D  
Alternate - 22"W x 30"H x 8"D

**Hydraulic Power Unit**  
24 1/4"W x 33 1/2"H x 12 3/4"D

### Notes:

- 1) The elevator machine room location and layout must meet the code requirements defined by the local authority having jurisdiction.
- 2) 30" wide x 36" deep clear working space in front of the motor controller as required by National Electrical Code (NFPA 70).
- 3) The light switch must be located on the strike side of the machine room door.
- 4) The hydraulic power unit must be located within 40'0" of the cylinder.
- 5) The machine room must be free of all equipment not related to the elevator.
- 6) The machine/control room temperature must be maintained between 50°F and 80°F.

\*Feeding breaker must not be a GFCI

# Winding Drum Drive Machine room

## Machine Room

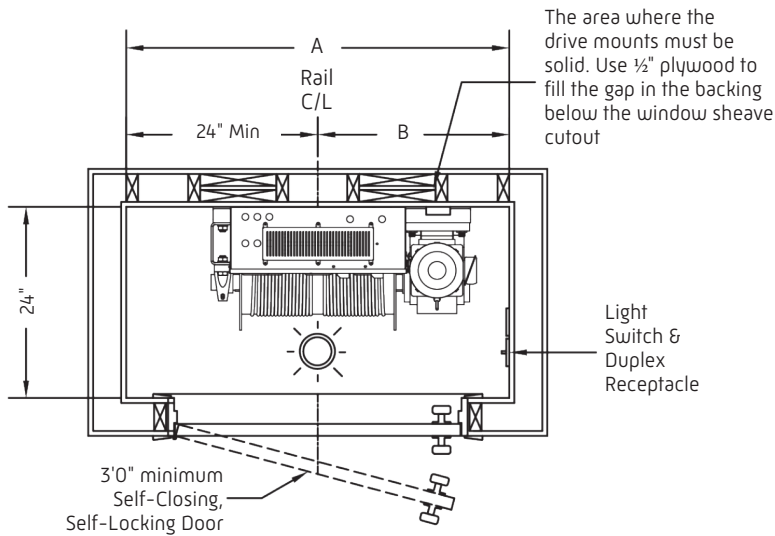

## Window Sheave Cutout Detail

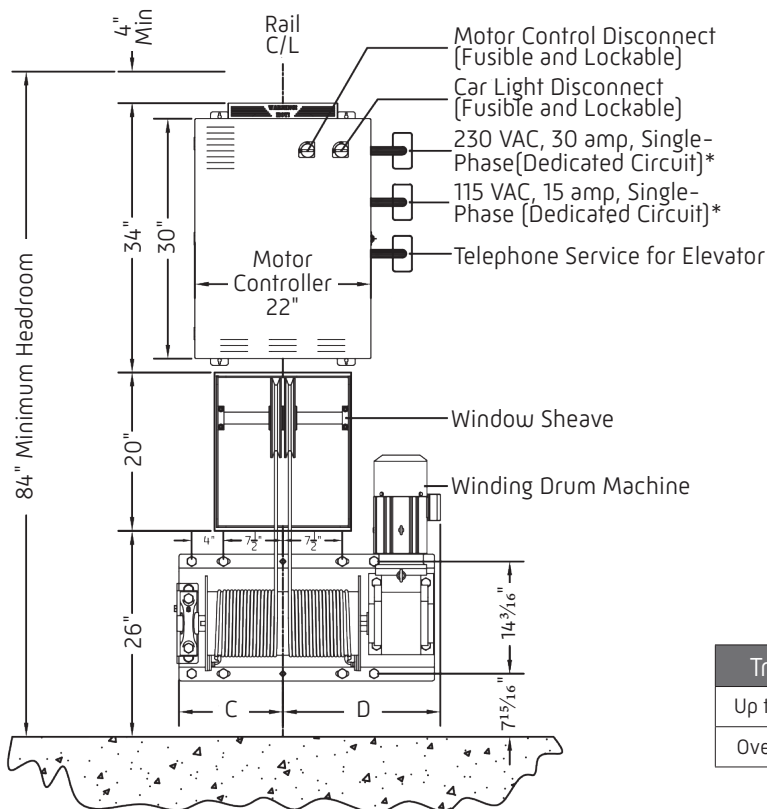
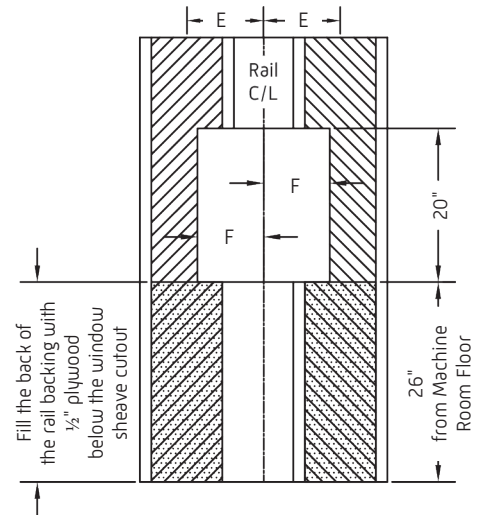

### Notes:

- 1) The elevator machine room location and layout must meet the code requirements defined by the local authority having jurisdiction.
- 2) 30" wide x 36" deep, clear working space in front of the motor controller as required by National Electrical Code [ NFPA 70].
- 3) The light switch must be located on the strike side of the machine room door.
- 4) The machine room must be free of all equipment not related to the elevator.
- 5) The machine/control room temperature must be maintained between 32°F and 80°F.

\*Feeding breaker must not be a GFCI

### Travel - Specific Dimensions

Travel	A	B	C	D	E	F
Up to 30'0"	48" min	24" min	13 1/8"	19 7/8"	10"	8 3/4"
Over 30'0"	60" min	36" min	19 5/16"	28 3/16"	12"	13"



## AIA Continuing Education

[symmetryelevator.com/aia](https://symmetryelevator.com/aia)

Symmetry offers courses to obtain continuing education credits. Each completed course is worth 1 (one) LU|HSW credit. Choose from a detailed review of residential elevators, vertical platform lifts (VPLs), limited use/limited application (LULA) elevators or vertical reciprocating conveyors (VRCs).

The courses also address: code application, specification, suitability of product type, the direct governance guidelines of ADA, ANSI and ASME, and site conditions required for a successful final installation.