

Winding Drum Drive

For Residential Applications



Industry Leading Warranty

- Three-year limited parts
- Extended warranty available

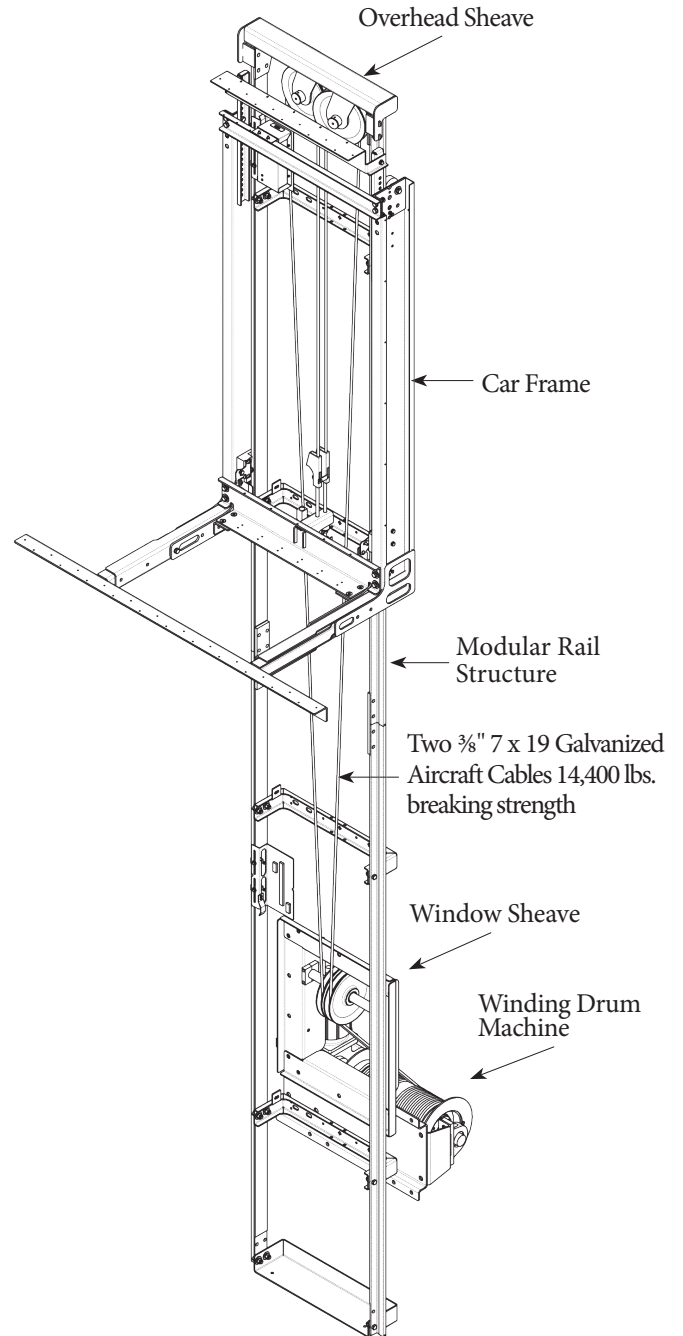

Proudly Made in the U.S.A.



Winding Drum Drive

Time tested and technology approved, the Winding Drum Drive is a versatile and efficient addition to any home.

This brochure is intended for INFORMATIONAL PURPOSES ONLY and SHOULD NOT be used for construction.

Standard Features

- Travel: Maximum of 50'0" (minimum 12 inches between stops)
- Speed: 40 fpm
- Rated Capacity: 1,000 lbs.
- Pit Depth: 6" minimum (8 inches preferred)
- Stops: Two
- Opening: Single
- Overhead: Minimum of 7'10" (94 inches) with a 7'0" interior car height
- Warranty: Three-year limited parts

Safety Features

- Slack rope safety device
- Two upper and one lower final limits
- Motor controller supply disconnects (located in controller)
- Car light supply disconnects (located in controller)
- Pit stop switch
- Car-top stop switch
- In-car emergency stop switch and alarm
- Safety switch for car gates/doors
- Battery backup emergency car lights and alarm
- Electro-mechanical hoistway door locking devices (doors by others)
- Enhanced gate/bypass monitor
- Unauthorized hoistway entry detection

Controls

- Programmable Logic Controller (PLC)
- Non-selective collective automatic operation
- S.M.A.R.T. system (Self-Monitoring Alert Response Technology)*
- Car Operating Panel (COP) with LED floor position indicator§
- Recessed phone box (phone jack included)§
- Hall stations with call button and LED floor position indicators
- Automatic car lighting
- Single floor designated car homing
- Uninterruptible Power Supply (UPS) for car lowering and automatic car gate/door operation (if provided) in the event of a power failure*

Car Features

- Car size up to 15 square feet
- 7'0" interior car height
- Birch or Red Oak flat veneer interior walls with flat ceiling*
- Matching wood handrail
- Matching wood car sill
- Unfinished plywood floor with sill set for ¾" (flooring by others)
- Two energy-saving recessed LED lights with Black trim rings
- Light Oak, Birch or White 7'0" laminate accordion door

Equipment

- Modular 6¼ lb. T-rail structure
- Car frame assembly
- 208/230 VAC, 60 Hz, 30 amp, single-phase power supply for motor controller
- 120 VAC, 60 Hz, 15 amp, single-phase power supply
- Code-compliant electrical disconnects included*
- Two ¾" 7 x 19 galvanized aircraft cables (14,400 lbs. breaking strength) with wedge rope shackles
- Inverter-controlled variable speed Winding Drum Drive unit and 3 HP motor
- Manual lowering device

Optional Features

- Up to six stops
- Single automatic push-button operation
- Custom car size up to 18 square feet**
- Custom car heights
- Shaker or Recessed panel car with flat ceiling
- Shaker, Recessed or Raised panel car with matching ceiling
- Four recessed LED lights with Black, White, Polished Brass, Brushed Nickel or Bronze trim rings
- Factory-finished car
- Fixtures including COPs, hall stations, phone boxes and handrails available in:
 - Polished or Blackened Stainless Steel
 - Brushed, Polished or Oil-Rubbed Solid Brass
 - Powder-coated Steel
- COP with integrated keypad phone
- Custom wood interiors
- ¾ inch finished or unfinished installed hardwood car flooring
- Custom sill heights
- Buffer springs (require minimum of 7¼ inch pit depth)
- Key switch for COP and/or hall stations
- Light curtain monitoring the car entrance
- Rated capacity: 750 lbs.
- Symmetry Locking Device (SLD)
- Extended warranty

Car Gate/Door Options

- Symmetry Safety 3-Panel car door
- Two or three speed car door or car and landing doors
- Enterprise collapsible gate
- Dark Oak, Chalk, Antique White, Cherry, Walnut or Black laminate accordion door
- Hardwood veneer accordion door
- Clear or Bronze acrylic panel accordion door
- Automatic car gate/door operator (not available on the Enterprise collapsible gate)
- 1½ hour fire-rated steel door (B-Label)



Visit symmetryelevator.com to view the Residential Elevator Brochure, Design Guide, specification, typical drawings and more

* Symmetry Elevating Solutions exclusive

** May require approval from the local authority having jurisdiction and effect capacity

§ Standard finish is Brushed Stainless Steel, but multiple finishes available